

REV.	ECN NO.	MODIFY MATTER	DATE	APPROVED
A		RELEASE TO PRODUCTION		

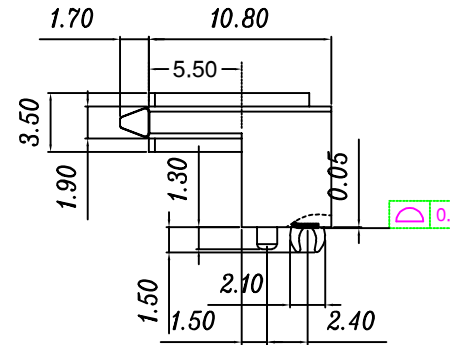

NOTES:
 1.MATERIAL:
 HOUSING:LCP G/F UL94 V-0
 COLOR:BLACK
 CONTACT:BRASS T=0.25mm
 PEG:BRASS T=0.30mm
 2.FINISH:
 CONTACT:GOLD FALSH/TIN PLATING ON CONTACT AREA
 100u" MIN.TIN PLATING ON SOLDERTAILS
 50u" MIN.NICKEL UNDERPLATING OVER ALL
 PEG:100u"MIN.TIN PLATION ON SOLDERTAILS
 50u"MIN.TIN NICKEL UNDERPLATING OVER ALL

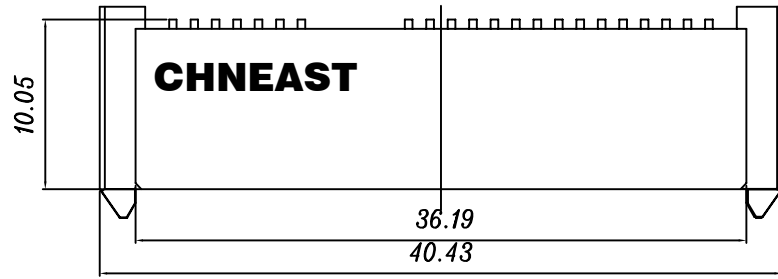
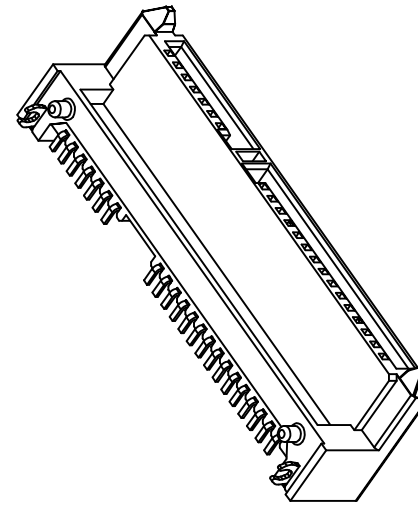
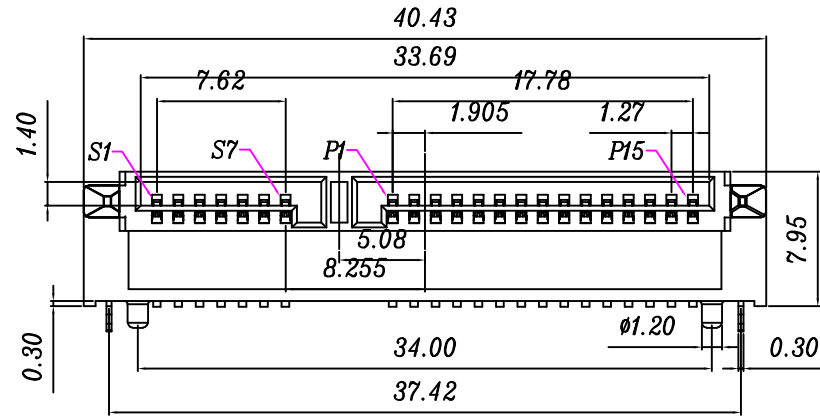

EAST-SA90SDS795LDBR

塑胶高度: H7.95mm
 包装方式:
 A:管装
 B:卷盘
 C:吸塑盘

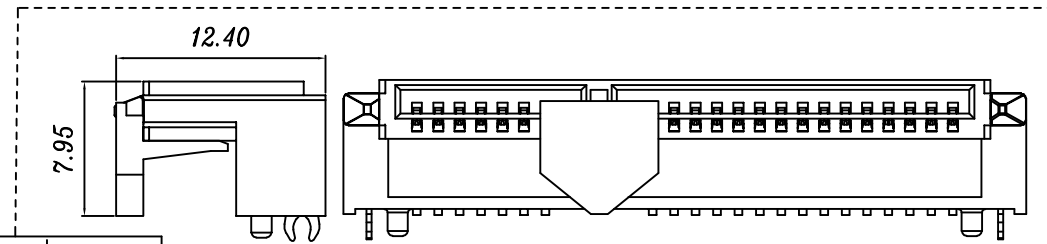
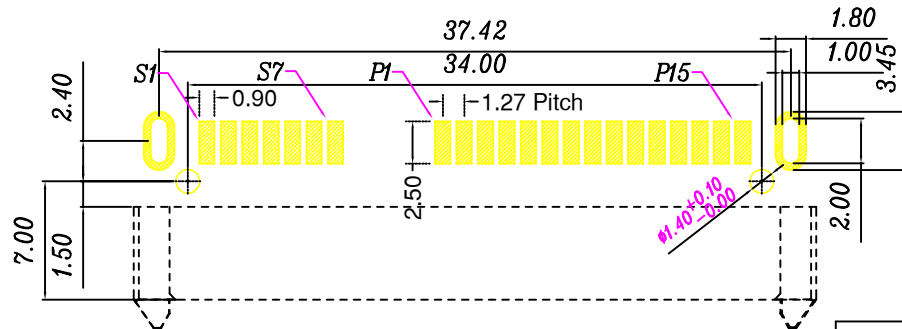

Signal Segment Name	Type
S1	GND
S2	A+
S3	A-
S4	GND
S5	B-
S6	B+
S7	GND

Power Segment			
Name	Type	Name	Type
P1	V3.3	P9	V5
P2	V3.3	P10	GND
P3	V3.3	P11	DAS/DSS
P4	GND	P12	GND
P5	GND	P13	V12
P6	GND	P14	V12
P7	V5	P15	V12
P8	V5		

TOLERANCES UNLESS OTHERWISE SPECIFIED:
 X. ---
 X. X ± 0.38
 X. XX ± 0.25
 X. XXX ± 0.10
 Angle ± 1°

THESE DRAWING AND SPECIFICATION ARE THE PROPERTY OF Shenzhen Dongfangyue ELECTRONIC CO., LTD. SHALL NOT BE REPRODUCED.

COSTOMER COPY		深圳市东方御业科技有限公司 WWW.DFYCONN.COM TEL:0755-27155560	
DRAWN: CHENLEI	2017/09/10	TITIAL: SATA 7+15P F R/A板下SMT型 塑高H7.95mm (RoHS)	
CHECKED: CHENLEI	2017/09/10	PART NO: EAST-SA90SDS795LDBR	
APPROVED: QINKAIXING	2017/09/10	UNIT: mm	SCALE: N/A
		SHEET: 1:1	REV.

REV.	ECN NO.	MODIFY MATTER	DATE	APPROVED
A		RELEASE TO PRODUCTION		

包装说明:

1. 将合格产品放置在卷带内,每1卷装350PCS产品,再将卷带绕在盘内如图所示。
2. 再将卷盘叠起,每箱6盘放入纸箱内,每箱总计装2100PCS产品
3. 纸箱规格350mm*350mm*385mm

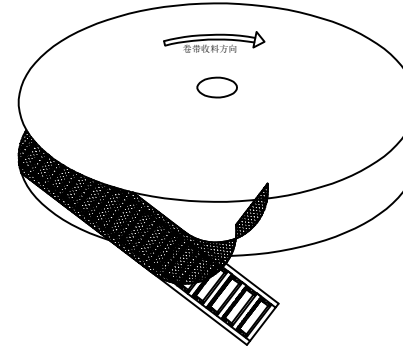
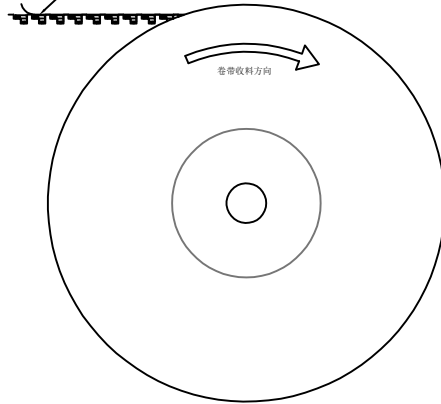
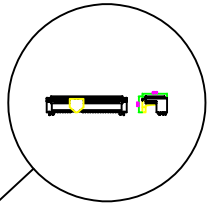
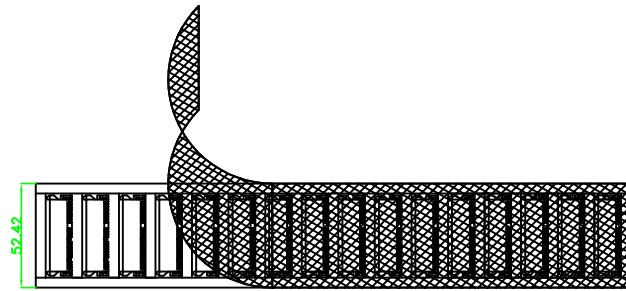

SCALE 2:1

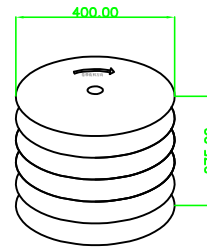

SCALE 5:1

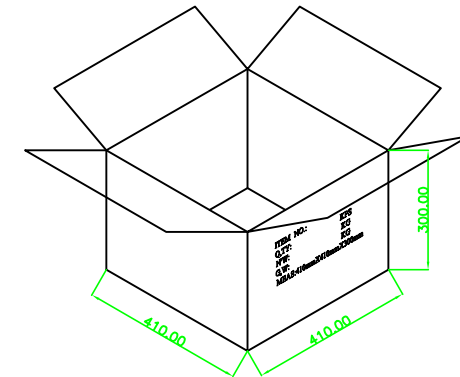

SCALE 5:1

TOLERANCES UNLESS OTHERWISE SPECIFIED: X. --- X. X ± 0.38 X. XX ± 0.25 X. XXX ± 0.10 Angle ± 1°	COSTOMER COPY		深圳市东方御业科技有限公司 WWW.DFYCONN.COM TEL:0755-27155560			
	DRAWN:	CHENLEI	2017/09/10	TITIAL: SATA 7+15P F R/A板下SMT型 塑高H7.95mm包装图 (RoHS)		
	CHECKED:	CHENLEI	2017/09/10	PART NO: EAST-SA90SDS795LDCR		
	APPROVED:	QINKAIXING	2017/09/10	UNIT: mm	SCALE: N/A	SHEEL: 1:1